

TECHNICAL BULLETIN:

Reactor Loading Procedure for CRITERION* Tail Gas Catalyst

Criterion 234 and 534 tail gas catalysts are used in many Claus tail gas reduction reactors such as SCOT7 (Shell Claus Offgas Treating), Beavon7, and proprietary design processes. To operate at optimum efficiency, certain guidelines must be followed when loading tail gas reduction reactors.

FLAT OR "PANCAKE" REACTORS (Figure 1)

The use of catalysts other than the main bed catalysts and support material should be dictated by the available free volume of the reactor.

Top Layer - 8 cm (3 inches) minimum of 12 mm (1/2 inch) spherical top-bed hold-down dense material such as Norton Denstone or equivalent.

Next Layer - 8 cm (3 inches) of 8 mm Criterion 534 or Criterion 514 spherical "active support" catalyst.

Main Bed -- Criterion 234 or 534. The minimum volume of Criterion tail gas catalyst should equal the volume of main bed catalyst which is specified by the process licensor.

Intermediate Layer -- 8 cm (3 inches) of 8mm Criterion 534 or Criterion 514 spherical "active support" catalyst.

Bottom Layer -- on the bottom screen use a minimum layer of 8 cm (3 inches) of 12 mm (1/2 inch) dense ceramic spheres.

RADIAL FLOW REACTORS

Catalyst drain spouts should be filled with 1/2 inch spherical inert material such as Norton Denstone or equivalent. Under no circumstances should the inert material be used in the flow path of the reactor to attempt to provide a level bed for the catalyst, because some of the process flow would then be allowed to bypass the catalyst bed.

Criterion 534 (4.0) is recommended for radial-flow reactors because minimum pressure drop and maximum strength will be provided.

Radial-flow reactors should include a "blinded-off" volume at the top of the reactor. This blinded-off volume should be filled with main bed catalyst, not inert material.

Trademark*

TYPICAL TAIL GAS REACTOR LOADING

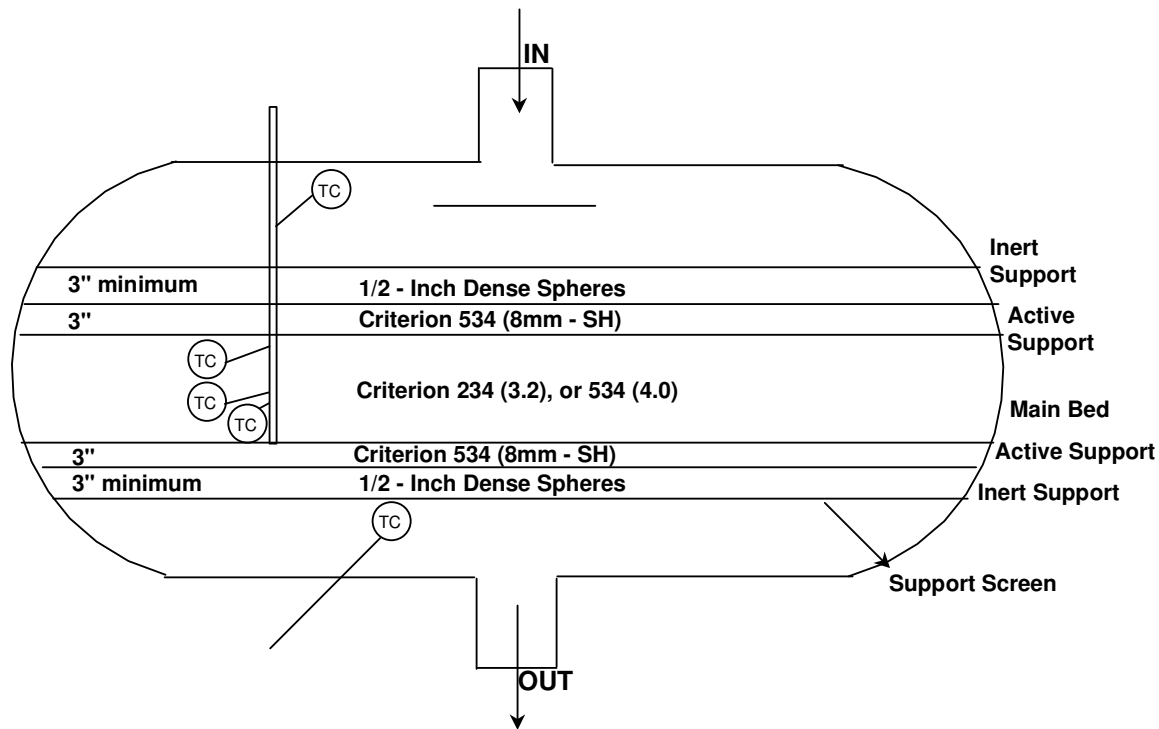

REACTOR SCREENS

Before loading, the catalyst screens should be carefully inspected, e.g. holes, areas of poor contact with reactor wall, etc. in order to ensure that no catalyst leaks will occur.

REACTOR THERMOCOUPLES

The proper placement of thermocouples in the tail gas reactor permits optimum monitoring of the tail gas reduction catalyst during the sulfiding of the catalyst prior to use and during the routine operation of the process.

Bed Inlet -- Ideally one thermocouple should be placed within the body of the reactor upstream of the catalyst bed. This permits the determination of the actual bed inlet temperature.

Catalyst Bed -- Thermocouples should be placed in groups of three within the main catalyst bed parallel to the direction of flow about 15 cm (6 inches) from the inlet, mid-bed, and 15 cm (six inches) before the outlet of the bed. This arrangement permits the monitoring of the progression of the reaction.

Bed Outlet -- One thermocouple should be placed within the reactor body downstream of the catalyst bed. This thermocouple will indicate the actual catalyst bed outlet temperature.

GENERAL

At your request, specific loading recommendations and a catalyst loading diagram will be supplied as part of your catalyst purchase.

HEALTH, SAFETY, AND ENVIRONMENTAL PRECAUTIONS

CRITERION hydrotreating catalysts are made from chemicals which span a range from being almost non-toxic to being potential carcinogens. Full attention to these hazards and to appropriate precautions and preventative measures is essential. Before ordering, testing, loading, or using these catalysts, be sure to obtain available information on health, safety, and environmental hazards, precautions and preventative measures from your CRITERION Catalysts Representative.

ADDITIONAL INFORMATION

All catalyst information supplied by CRITERION is considered accurate but is furnished with the express understanding that the customer receiving such information shall make its own assessments to determine suitability of such information for customer's particular purpose. All purchases of catalyst from CRITERION are subject to CRITERION's standard terms and conditions of sale (including CRITERION's product warranties) set forth in a sales proposal, sales contract, order acknowledgement, and/or bill of lading.

HOUSTON:

16825 Northchase Drive, Suite 1000
Houston, Texas 77060-6029
Telephone: (1) 281- 874-2600
Telefax: (1) 281- 874-2641

ENGLAND:

1650 Parkway
The Solent Business Park,
Whiteley, Fareham
Hampshire, PO15 7AH England
Telephone: (44) 1 489-881881
Telefax: (44) 1 489-881882

CANADA:

5241 Calgary Trail Southbound
Centre 104, Suite # 810
Edmonton, Alberta T6H 5G8
Telephone: (1) 780-438-4188
Telefax: (1) 780-438-3473

SINGAPORE:

298 Tiong Bahru Road
#07-03 Central Plaza
Singapore 168730
Telephone: (65) 6276-3627
Telefax: (65) 6276-7455

DUBAI:

10th Floor, Dubai Convention Tower
Zabeel Area
Dubai, UAE
Telephone: +971 4 4405 4640
Telefax: +971 4 4405 4656

EMAIL: CriterionPublicAffairs@cri-criterion.com